

RTG006 – USB connected Virtex-4 FX System

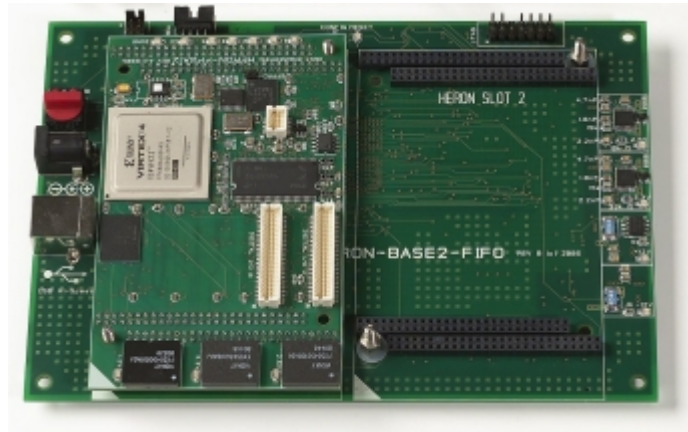

- User programmable Xilinx XC4VFX12 FPGA with embedded PowerPC processor.
- 128Mbytes of DDR SDRAM connected as 32Mx32 @ 200Mhz
- 16Mbytes of FLASH memory for PowerPC code storage
- 60 bits programmable digital I/O
- Hi Speed (480Mbits/sec) USB 2.0 connection to a host PC
- Can be used as a stand alone board for embedded systems.
- FPGA can be configured via USB, Xilinx JTAG cable or from on-board PROM
- Single 5V power supply required – 20W mains Power Supply Unit included
- HUNT ENGINEERING Host API supported for Windows 2000 and XP – FPGA and DSP loading, resetting and data exchange all performed with simple to use software interface.
- Optional expansion via HERON module slot – see www.hunt-dsp.com for options

The RTG006 is a self contained system combining FPGA hardware and a programmable embedded PowerPC. It also offers 128Mbytes of DDR SDRAM with a 1.6Gbytes total memory bandwidth. VHDL support is included for connecting this DDR memory to the Embedded PowerPC processor AND your VHDL design at the same time.

16Mbytes of FLASH memory is connected to the FPGA - intended for PowerPC code storage.

The system can be used stand alone or connected to a PC via the USB 2.0 connection.

The FPGA can be programmed with your own design, allowing whatever function you need, and connectivity to the embedded PowerPC processor. This allows you to develop an embedded design that uses FPGA hardware and PowerPC processor in the correct mix for your particular needs.

The USB connection is supported via the HUNT ENGINEERING Host-API software. This allows software applications and tools on the Host PC to access the hardware using a consistent software interface without the need to understand or program the hardware or USB directly

The FPGA program can be loaded over the USB connection using a software tool that directly accepts the output from development tools for the Xilinx FPGA. Alternatively a Xilinx JTAG cable (Parallel or USB) can be used to load the FPGA and or program the on board configuration PROM. The PowerPC program can be downloaded as part of the FPGA design or after the FPGA configuration using the GNU debugger or the HERON FIFOs or can be loaded from the FLASH memory provided on the module.

The FIFO connections can be used to stream data between the PC and the FPGA. They are capable of up to 50Mbytes/second in each direction, but the Host PC, its USB controller and the operating system will all impose their own limits to this speed.

The system is delivered ready to go with a power supply (requires an IEC lead specific to your country), USB cable, I/O cables and a CD with all of your documentation, software tools and examples. The only other thing you need are development tools for the Xilinx FPGA, for example Xilinx Foundation ISE from www.xilinx.com and Xilinx EDK for programming the PowerPC.

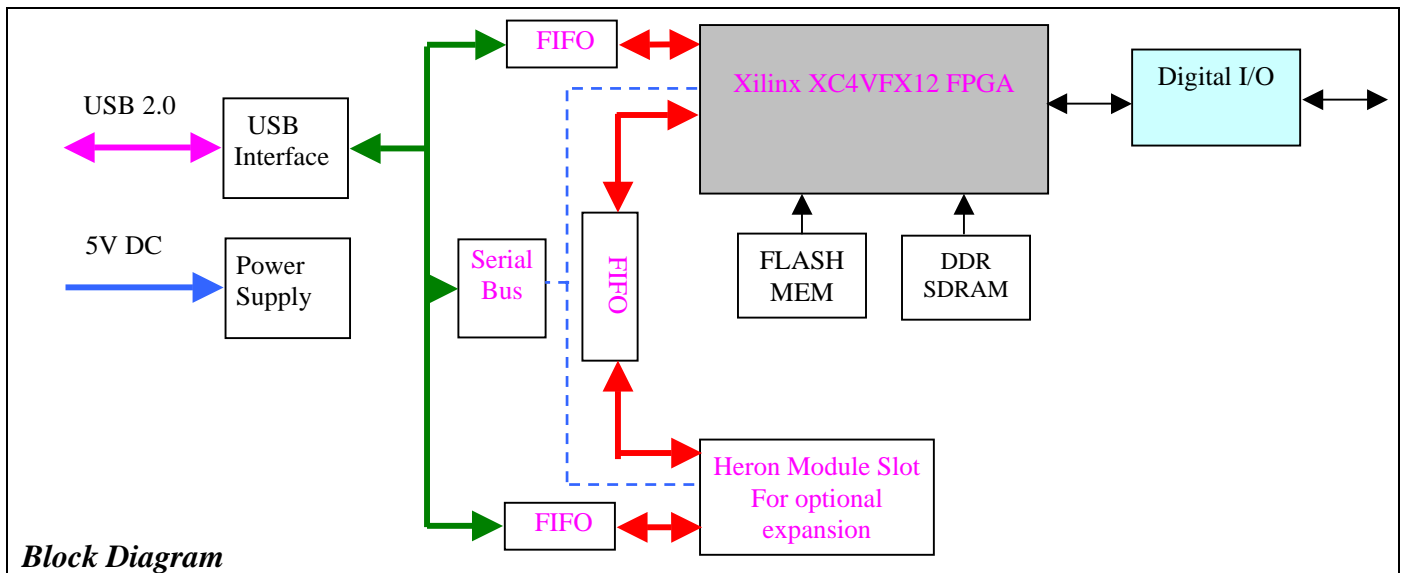

Technical Specification

FPGA

Xilinx XC4VFX12, Virtex-II Pro FPGA logic with PowerPC hard core
 With no heatsink fitted (standard) the FPGA can dissipate 2.4 Watts at 50deg C ambient temperature.
 The power circuits are capable of delivering more than this, so a heatsink may be required for your design.
 If that is the case a larger 5V Power Supply Unit may also be necessary

Memory

DDR SDRAM 128Mbytes organised as 32M x 32 at 200Mhz
 Flash 16Mbytes – byte wide

Host Bus

USB 2.0 capable of up to 50Mbytes/second dependent on host PC and USB configuration.

Maximum Dimensions:

160mm x 110mm x 21mm.

Power requirements

5V Max: 1.55A plus the power taken by the FPGA. Typ: 1.15A plus FPGA

The Mains PSU included can supply up to 4A, which is enough to power an FPGA design that is less than the 2.4W bare package maximum dissipation.

HUNT ENGINEERING acknowledges all Trademarks used in this document.
 This document does not form part of a contract, HUNT ENGINEERING reserves the right to change product specifications without notice and to refuse to supply any item detailed on this data sheet E&OE. Rev 1.0

Distributor details: