

RTG005 – USB connected FPGA and PowerPC Image Processing System

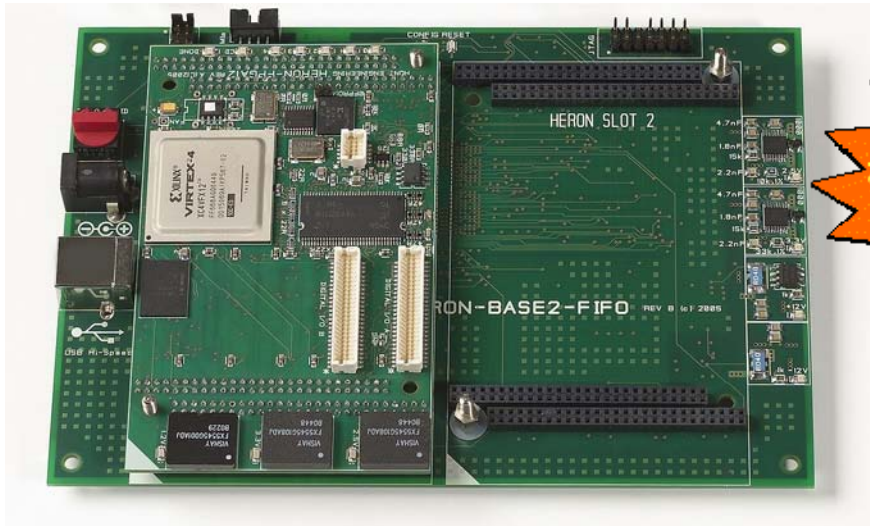

£1,600

- CameraLink base connection for image capture from camera.
- User programmable Xilinx XC4VFX12 FPGA with embedded PowerPC processor.
- 128Mbytes of DDR SDRAM connected as 32Mx32 @ 200Mhz
- 16Mbytes of FLASH memory for PowerPC code storage
- Hi Speed (480Mbits/sec) USB 2.0 connection to a host PC
- Can be used as a stand alone board for embedded systems.
- FPGA can be configured via USB, Xilinx JTAG cable or from on-board PROM
- Single 5V power supply required – 20W mains Power Supply Unit included
- HUNT ENGINEERING Host API supported for Windows 2000 and XP – FPGA and DSP loading, resetting and data exchange all performed with simple to use software interface.
- Optional expansion via HERON module slot – see www.hunt-dsp.com for options

The RTG005 is a self contained FPGA system with a CameraLink connection. This, along with the provided examples, provides an ideal starting point for developing image processing systems. The FPGA contains an embedded PowerPC processor so your system can be realised with a combination of hardware processing programmed in VHDL and software processing programmed in C.

There is a 128Mbyte DDR memory that can be used for code storage as well as for frame storage. VHDL support is provided allowing access to this DDR memory from the Embedded PowerPC processor AND your VHDL design at the same time. The example provided has an FPGA design that performs a number of standard imaging functions in VHDL on the live image stream coming from a monochrome Camera. The processed images are streamed over the USB connection to a C program on the Host PC for display. All source code is provided so this can form the beginning of your development. You can extend the image processing to use the embedded PowerPC if required.

The system can be used stand alone or connected to a PC via the USB 2.0 connection. This connection can be used to send raw or processed images to the PC for storage or display. Alternatively control information can be sent to the system to allow user control etc. The USB FIFO connection is capable of up to 50Mbytes/second in each direction, but the Host PC, its USB controller and the operating system will all impose their own limits to this speed.

The USB connection is supported via the HUNT ENGINEERING Host-API software. This allows software applications and tools on the Host PC to access the hardware using a consistent software interface without the need to understand or program the hardware or USB directly.

The system is delivered ready to go with a power supply (requires an IEC lead specific to your country), USB cable, I/O cables and a CD with all of your documentation, software tools and examples. The only other thing you need are development tools for the Xilinx FPGA, for example Xilinx Foundation ISE from www.xilinx.com and Xilinx EDK for programming the PowerPC.

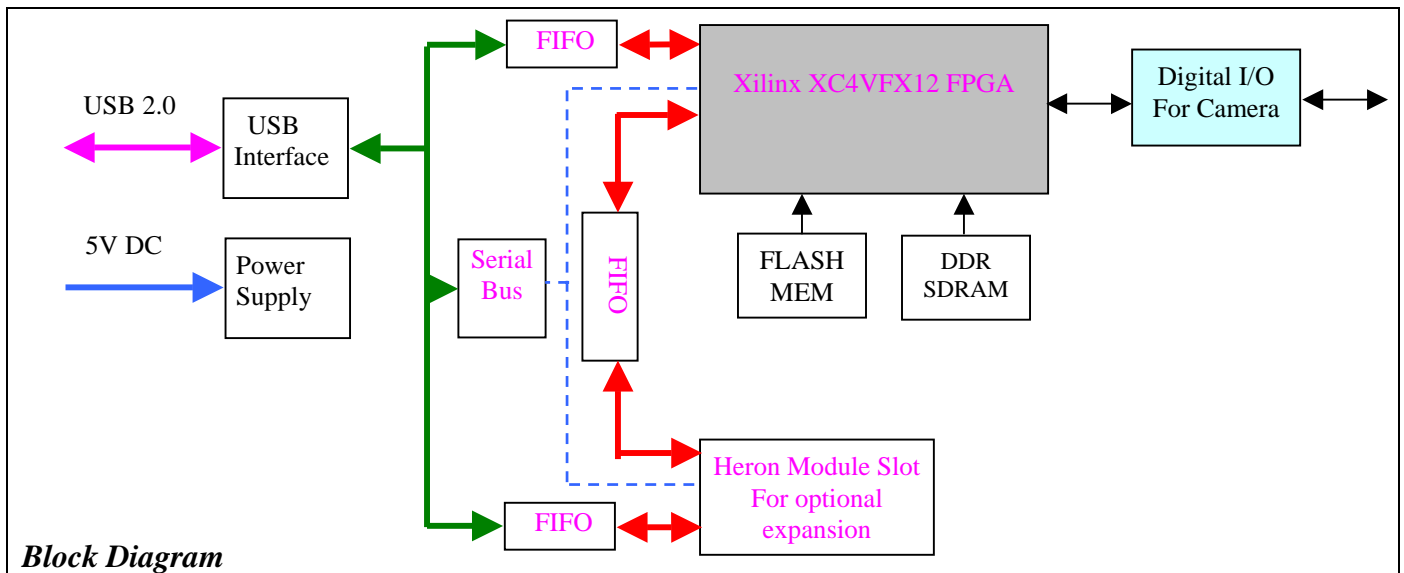

Technical Specification

FPGA

Xilinx XC4VFX12, Virtex-II Pro FPGA logic with PowerPC hard core
 With no heatsink fitted (standard) the FPGA can dissipate 2.4 Watts at 50deg C ambient temperature.
 The power circuits are capable of delivering more than this, so a heatsink may be required for your design.
 If that is the case a larger 5V Power Supply Unit may also be necessary

Memory

DDR SDRAM 128Mbytes organised as 32M x 32 at 200Mhz
 Flash 16Mbytes – byte wide

Host Bus

USB 2.0 capable of up to 50Mbytes/second dependent on host PC and USB configuration.

Maximum Dimensions:

160mm x 110mm x 21mm.

Power requirements

5V Max: 1.55A plus the power taken by the FPGA. Typ: 1.15A plus FPGA

The Mains PSU included can supply up to 4A, which is enough to power an FPGA design that is less than the 2.4W bare package maximum dissipation.

HUNT ENGINEERING acknowledges all Trademarks used in this document.
 This document does not form part of a contract, HUNT ENGINEERING reserves the right to change product specifications without notice and to refuse to supply any item detailed on this data sheet E&OE. Rev 1.0

Distributor details: