

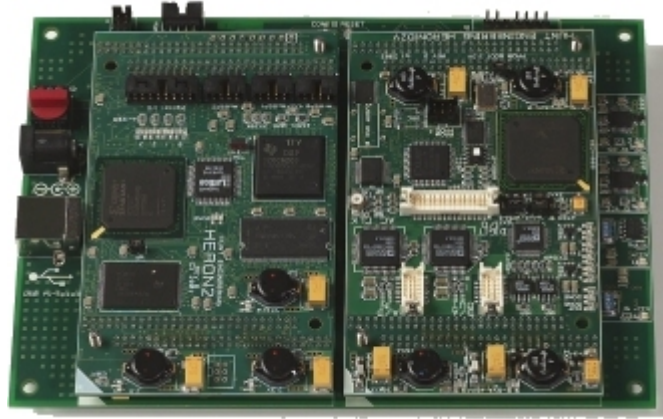

RTG003 – Software Defined Radio Development System



- User programmable Xilinx XC2V1000-4 FPGA.
- 2 channels of 125Mhz 12 bit A/D
- 2 channels of single ended 125Mhz 14 bit D/A
- 8 bits digital I/O
- User programmable 300Mhz TMS320C6203 16 bit fixed point DSP
- 32Mbytes SDRAM coupled with the DSP plus 2Mbytes Flash ROM for DSP booting and N/V storage
- Hi Speed (480Mbits/sec) USB 2.0 connection to a host PC
- Can be used as a stand alone board for embedded systems.
- FPGA can be configured via USB, Xilinx JTAG cable or from on-board PROM
- Single 5V power supply required – 20W mains Power Supply Unit included
- HUNT ENGINEERING Host API supported for Windows 2000 and XP and Linux – FPGA and DSP loading, resetting and data exchange all performed with simple to use software interface.

The RTG003 is a self contained programmable system ideal for developing Software Defined Radio. It can be used stand alone or connected to a PC via the USB 2.0 connection.

The fast A/D and D/A channels are directly connected to the user programmable FPGA, allowing data to be processed by a user FPGA program. The FPGA can be used to perform digital processing between the analogue inputs and outputs, or the data can be passed to and from the DSP or a PC using the USB 2.0 connection and provided software.

The DSP can be programmed to perform whatever tasks you need – the supplied example uses the FPGA to make a Digital Down Conversion (DDC), the results of which are passed to the DSP for protocol processing. The DSP then outputs its results to the PC where a C++ program receives processes and graphs the data.

HUNT ENGINEERING supply Hardware Interface Layer VHDL for the FPGA and HERON-API for the DSP – speeding your development by allowing you to concentrate on your algorithms.

The USB connection is supported via the HUNT ENGINEERING Host-API software. This allows software applications and tools on the Host PC to access the hardware using a consistent software interface without the need to understand or program the hardware or USB directly.

The FPGA program can be loaded over the USB connection using a software tool that directly accepts the output from development tools for the Xilinx FPGA. Alternatively a Xilinx JTAG cable (Parallel or USB) can be used to load the FPGA and or program the on board configuration PROM.

The DSP program can be loaded over the USB connection using a software tool that directly accepts the output from development tools for the TI DSP. Alternatively a JTAG emulator card can be used to load the DSP and or program the on board FLASH memory.

The FIFO connections can be used to stream data to or from a module in the system. They are capable of up to 50Mbytes/second in each direction, but the Host PC, its USB controller and the operating system will all impose their own limits to this speed.

The system is delivered ready to go with a power supply (requires an IEC lead specific to your country), USB cable, I/O cables and a CD with all of your documentation, software tools and examples. The only other thing you need are development tools for the Xilinx FPGA, for example Xilinx Foundation ISE from www.xilinx.com and a suitable 'C6000 JTAG emulator card with Code Composer Studio.

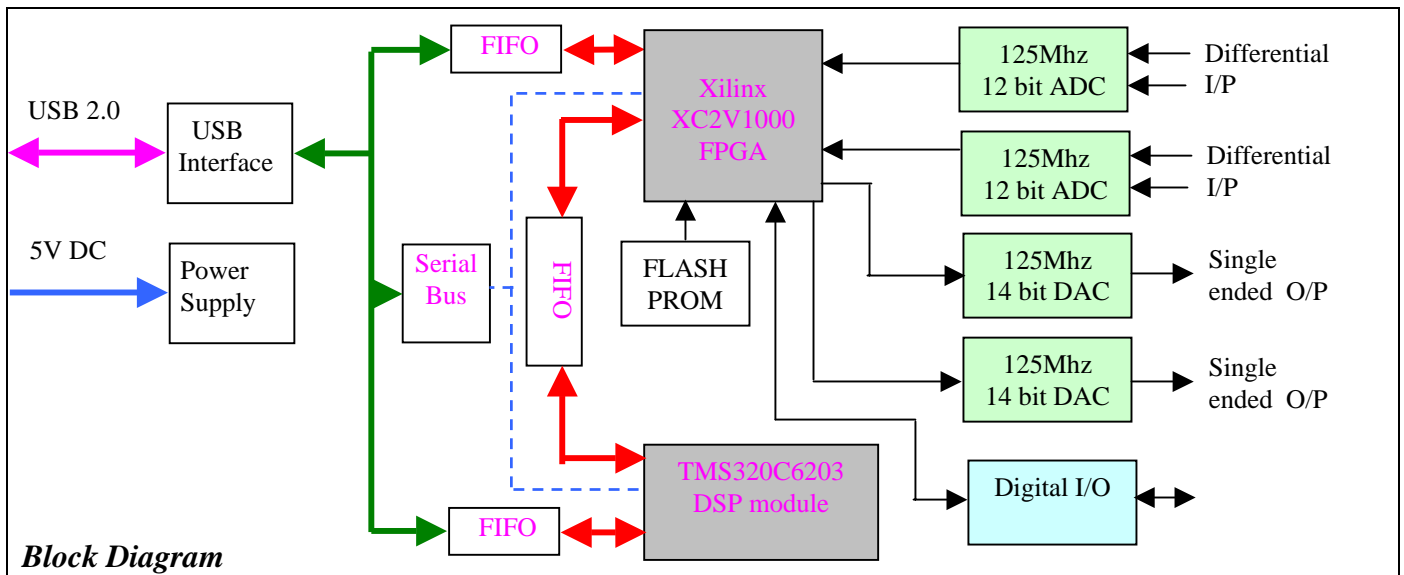

Technical Specification

Analogue I/P

2 channels with common or independent clocking set by jumper

Standard Input characteristics:

A/C coupled 50R, signal B/W from 750Hz to 500Mhz

Zero input noise typically 3 levels maximum 8 levels

Offset typically +3 levels maximum +-12 levels

Optional Input types:

A/C coupled as standard but choose I/P impedance from 50R to 1K

D/C

D/C coupled choose I/P impedance from 50R to 1K, Signal B/W 0hz to 500Mhz but each input must not exceed the range 0v to +5V (of this module). This means a 4V DC offset is required.

Zero input noise typically 3 levels maximum 8 levels

Offset typically +12 levels maximum +-16 levels

Analogue O/P specifications

Standard Output characteristics:

2 single ended channels with independent clocking

A/C coupled 10R, signal B/W from 1250Hz to 145Mhz

Optional Output types:

D/C coupled 10R, signal B/W 0 – 145Mhz

FPGA

Xilinx 1M gate Virtex-II FPGA, speed grade 4. XC2V1000-4FG456

With no heatsink fitted (standard) the FPGA can dissipate 2.4 Watts at 50deg C ambient temperature.

The power circuits are capable of delivering more than this, so a heatsink may be required for your design.

If that is the case a larger 5V Power Supply Unit may also be necessary

DSP

Texas Instruments' 'C6203 @ 300Mhz, 32Mbytes SDRAM, 2 Mbytes Flash ROM

4 bit digital Outputs, 4 bit digital Inputs, 2 McBSPs

Host Bus

USB 2.0 capable of up to 50Mbytes/second dependent on host PC and USB configuration.

Maximum Dimensions:

160mm x 110mm x 21mm.

Power requirements

5V Max: 3.5A plus the power taken by the FPGA. Typ: 2.6A plus FPGA

The Mains PSU included can supply up to 4A, which is enough to power an FPGA design that is less than the 2.4W bare package maximum dissipation.

HUNT ENGINEERING acknowledges all Trademarks used in this document. This document does not form part of a contract, HUNT ENGINEERING reserves the right to change product specifications without notice and to refuse to supply any item detailed on this data sheet E&OE. Rev 1.0

Distributor details: