



RTG002 – USB connected Digital I/O & FPGA System



- User programmable Xilinx XC2V1000-4 FPGA.
- 90 bits programmable single ended/differential digital I/O
- Hi Speed (480Mbits/sec) USB 2.0 connection to a host PC
- Can be used as a stand alone board for embedded systems.
- FPGA can be configured via USB, Xilinx JTAG cable or from on-board PROM
- Single 5V power supply required – 20W mains Power Supply Unit included
- HUNT ENGINEERING Host API supported for Windows 2000 and XP – FPGA and DSP loading, resetting and data exchange all performed with simple to use software interface.
- Optional expansion via HERON module slot – see www.hunt-dsp.com for options

The RTG001 is a self contained programmable digital I/O system. It can be used stand alone or connected to a PC via the USB 2.0 connection.

The FPGA I/Os are directly connected to the Digital I/O connectors. This allows the FPGA design to use them as Single ended or differential signals with any mix of inputs and outputs. For LVDS differential inputs termination resistors must be fitted at build time, so you need to specify how many LVDS inputs you will use when you order your system.

Several FPGA designs are provided as starting points for your FPGA design, offering different mixes of inputs and outputs. The Virtex-II FPGA can be programmed to provide logic or data processing functions according to your needs.

The USB connection is supported via the HUNT ENGINEERING Host-API software. This allows software applications and tools on the Host PC to access the hardware using a consistent software interface without the need to understand or program the hardware or USB directly

The FPGA program can be loaded over the USB connection using a software tool that directly accepts the output from development tools for the Xilinx FPGA. Alternatively a Xilinx JTAG cable (Parallel or USB) can be used to load the FPGA and or program the on board configuration PROM.

The FIFO connections can be used to stream data to or from a module in the system. They are capable of up to 50Mbytes/second in each direction, but the Host PC, its USB controller and the operating system will all impose their own limits to this speed.

The system is delivered ready to go with a power supply (requires an IEC lead specific to your country), USB cable, I/O cables and a CD with all of your documentation, software tools and examples. The only other thing you need are development tools for the Xilinx FPGA, for example Xilinx Foundation ISE from www.xilinx.com.

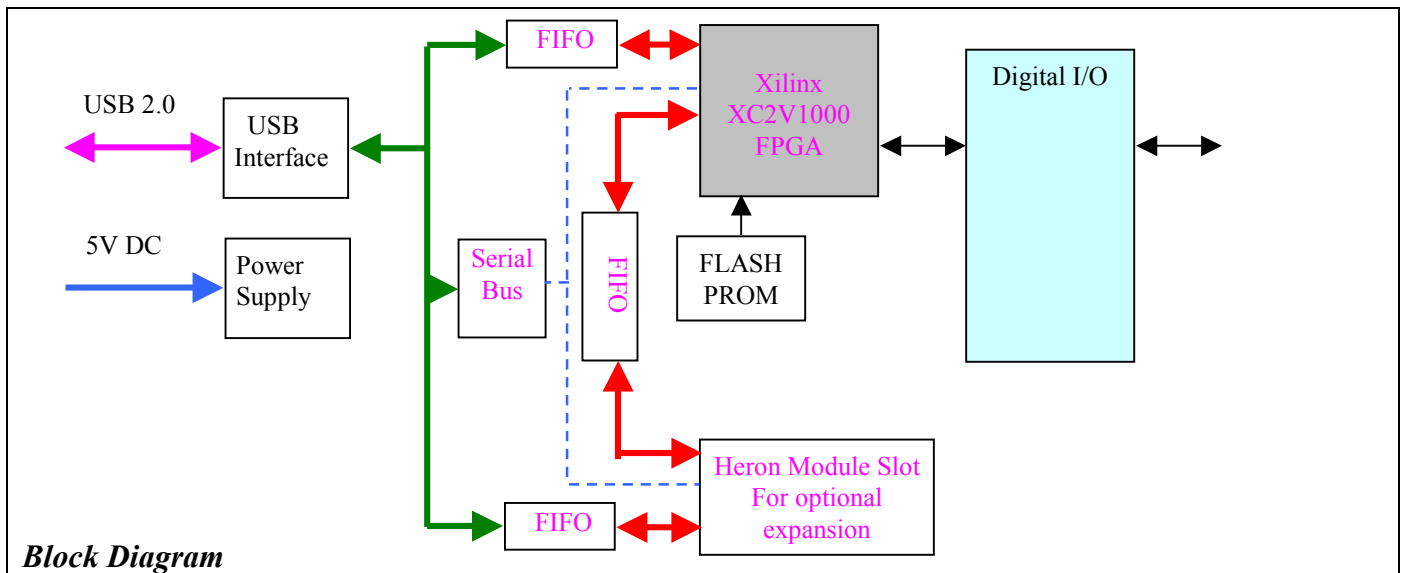

Technical Specification

FPGA

Xilinx 1M gate Virtex-II FPGA, speed grade 4. XC2V1000-4FG456
 With no heatsink fitted (standard) the FPGA can dissipate 2.4 Watts at 50deg C ambient temperature.
 The power circuits are capable of delivering more than this, so a heatsink may be required for your design.
 If that is the case a larger 5V Power Supply Unit may also be necessary

Host Bus

USB 2.0 capable of up to 50Mbytes/second dependent on host PC and USB configuration.

Maximum Dimensions:

160mm x 110mm x 21mm.

Power requirements

5V Max: 1.55A plus the power taken by the FPGA. Typ: 1.15A plus FPGA

The Mains PSU included can supply up to 4A, which is enough to power an FPGA design that is less than the 2.4W bare package maximum dissipation.

HUNT ENGINEERING acknowledges all Trademarks used in this document.
 This document does not form part of a contract, HUNT ENGINEERING reserves the right to change product specifications without notice and to refuse to supply any item detailed on this data sheet E&OE. Rev 1.0

Distributor details: